

### Features

- High speed switching
- Low on-resistance
- No secondary breakdown
- Low driving power
- Avalanche-proof

### Applications

- Switching regulators
- UPS (Uninterruptible Power Supply)
- DC-DC converters

### Maximum ratings and characteristic Absolute maximum ratings

(Tc=25°C unless otherwise specified)

Item	Symbol	Ratings	Unit	
Drain-source voltage	V <sub>DS</sub>	500	V	
Continuous drain current	I <sub>D</sub>	±16	A	
Pulsed drain current	I <sub>D(puls)</sub>	±64	A	
Gate-source voltage	V <sub>GS</sub>	±30	V	
Repetitive or non-repetitive	IAR*2	16	A	
Maximum Avalanche Energy	EAS*1	212.2	mJ	
Maximum Drain-Source dV/dt	dV <sub>DS</sub> /dt *4	20	kV/μs	
Peak Diode Recovery dV/dt	dV/dt *3	5	kV/μs	
Max. power dissipation	P <sub>D</sub>	Ta=25°C	2.02	W
		Tc=25°C	225	
Operating and storage temperature range	T <sub>ch</sub>	+150	°C	
	T <sub>stg</sub>	-55 to +150	°C	

\*1 L=1.52mH, V<sub>CC</sub>=50V, See to Avalanche Energy Graph \*2 T<sub>ch</sub> ≤ 150°C

\*3 I<sub>F</sub> ≤ -I<sub>D</sub>, -di/dt=50A/μs, V<sub>CC</sub> ≤ BV<sub>DSS</sub>, T<sub>ch</sub> ≤ 150°C \*4 V<sub>DS</sub> ≤ 500V

### Electrical characteristics (Tc =25°C unless otherwise specified)

Item	Symbol	Test Conditions	Min.	Typ.	Max.	Units
Drain-source breakdown voltage	V <sub>(BR)DSS</sub>	I <sub>D</sub> =250μA V <sub>GS</sub> =0V	500			V
Gate threshold voltage	V <sub>GS(th)</sub>	I <sub>D</sub> =250μA V <sub>DS</sub> =V <sub>GS</sub>	3.0		5.0	V
Zero gate voltage drain current	I <sub>DSS</sub>	V <sub>DS</sub> =500V V <sub>GS</sub> =0V			25	μA
		V <sub>DS</sub> =400V V <sub>GS</sub> =0V			250	
Gate-source leakage current	I <sub>GSS</sub>	V <sub>GS</sub> =±30V V <sub>DS</sub> =0V		10	100	nA
Drain-source on-state resistance	R <sub>DSON</sub>	I <sub>D</sub> =7A V <sub>GS</sub> =10V		0.35	0.46	Ω
Forward transconductance	g <sub>fs</sub>	I <sub>D</sub> =7A V <sub>DS</sub> =25V	7	14		S
Input capacitance	C <sub>iss</sub>	V <sub>DS</sub> =25V		1600	2400	pF
Output capacitance	C <sub>oss</sub>	V <sub>GS</sub> =0V		160	240	
Reverse transfer capacitance	C <sub>rss</sub>	f=1MHz		7	10.5	
Turn-on time t <sub>on</sub>	td(on)	V <sub>CC</sub> =300V I <sub>D</sub> =7A		18	27	ns
	t <sub>r</sub>	V <sub>GS</sub> =10V		16	24	
Turn-off time t <sub>off</sub>	td(off)	R <sub>GS</sub> =10 Ω		35	50	
	t <sub>r</sub>			8	15	
Total Gate Charge	Q <sub>G</sub>	V <sub>CC</sub> =250V		33	50	nC
Gate-Source Charge	Q <sub>GS</sub>	I <sub>D</sub> =14A		12.5	19	
Gate-Drain Charge	Q <sub>GD</sub>	V <sub>GS</sub> =10V		10.5	16	
Avalanche capability	I <sub>AV</sub>	L=1.52mH T <sub>ch</sub> =25°C	16			A
Diode forward on-voltage	V <sub>SD</sub>	I <sub>F</sub> =14A V <sub>GS</sub> =0V T <sub>ch</sub> =25°C		1.00	1.50	V
Reverse recovery time	t <sub>rr</sub>	I <sub>F</sub> =14A V <sub>GS</sub> =0V		0.65		μs
Reverse recovery charge	Q <sub>rr</sub>	-di/dt=100A/μs T <sub>ch</sub> =25°C		6.0		μC

### Thermal characteristics

Item	Symbol	Test Conditions	Min.	Typ.	Max.	Units
Thermal resistance	R <sub>th(ch-c)</sub>	channel to case			0.556	°C/W
	R <sub>th(ch-a)</sub>	channel to ambient			62.0	°C/W

### Outline Drawings [mm]

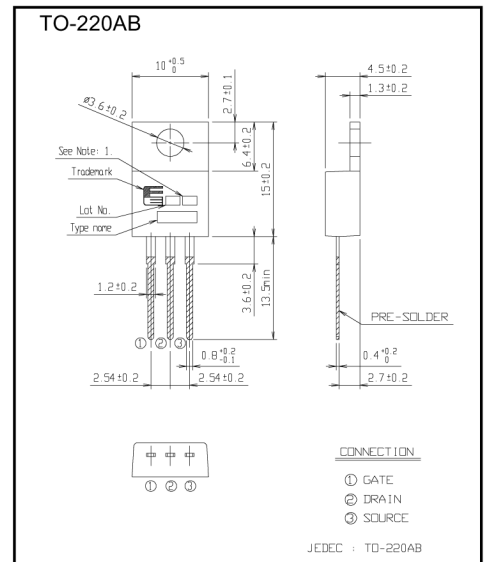

### Equivalent circuit schematic

